

Strainers [SEN]

Standard: EN

DN 15 ÷ DN 350

PN 16 ÷ PN 160

Design

- Forged or casted body and cover
- Bolted cover (BC)
- Net is safely build in between body and cover

Applications

- Power plant, Chemical, Petrochemical, Refining

Media

- Depending on the valve materials: water, steam, gas, oil and oil derivatives and other non aggressive media

Pressure and temperature (table C.1.9)

- Pressure up to 160 bar
- Temperature up to 600 °C

Materials (table C.1.1)

- Carbon, heat resistant alloy and stainless steels

Advantages

- Possibility of installation in any position
- Long service life
- Respect to emission standards
- Easy handling and maintenance

Options

- Threaded plug or valve installed on cover for quick draining
- Y-Type [SENY]
- Flanges and welding ends according to : ASME, DIN, GOST, etc.
- Other paint finishes are available upon customer's request
- Strainer complete with counter flanges, bolting and gaskets

Testing

- Every produced strainer was tested according to EN 12266

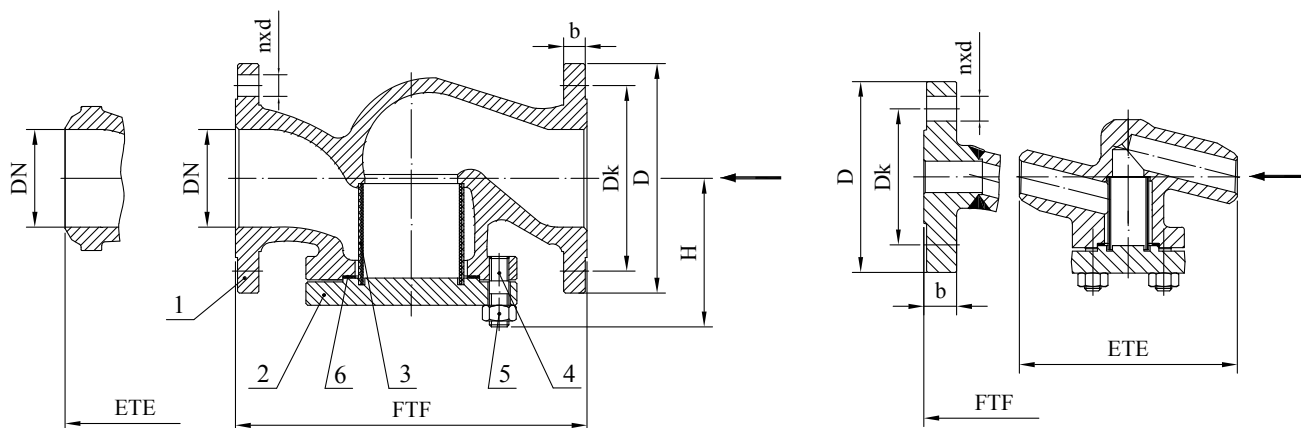

Drawing C.1.1 Parts and dimensions

List of materials

Table C.1.1

| Item | Part | Material Group acc. to EN 12516-1 | | | | | |
|------|----------------------|---|-------------------|---------------|------------------|-------------------|---------------|
| | | 3E0 | 4E0 | 5E0 | 6E0 | 11E0 | 15E0 / 14E0 |
| | | Application | | | | | |
| | | up to 400°C | up to 550°C | up to 550°C | up to 575°C | -196°C÷500°C | -196°C÷600°C |
| 1 | Body ⁽¹⁾ | 1.0460/1.0619 | 1.5415/1.5419 | 1.7335/1.7357 | 1.7383/1.7379 | 1.4301/1.4308 | 1.4571/1.4408 |
| 2 | Cover ⁽¹⁾ | 1.0460/1.0619 | 1.5415/1.5419 | 1.7335/1.7357 | 1.7383/1.7379 | 1.4301/1.4308 | 1.4571/1.4408 |
| 3 | Net | AISI 304 / AISI 316 | | | | | |
| 4 | Stud Bolts | A193 B7 / 1.7225 | A193 B16 / 1.7709 | | A193 B8 / 1.4301 | A193 B8M / 1.4401 | |
| 5 | Nuts | A194 2H / 1.1191 | A194 4 / 1.7709 | | A194 8 / 1.4301 | A194 8M / 1.4401 | |
| 6 | Covert Gasket | spiral-wound / reinforced pure graphite | | | | | |

⁽¹⁾other materials available according to EN standard

Standards

Table C.1.2

| Strainers according to EN standards | PN 16 / PN 25 / PN 40 | PN 63 / PN 100 / PN 160 |
|--------------------------------------|-----------------------|-------------------------|
| Face-to face dimensions according to | EN 558, Serie 1 | EN 558, Serie 2 |
| Flanged ends according to | EN 1092-1 | |
| End-to-end dimensions according to | EN 12982, Serie 64 | EN 12982, Serie 65 |
| Welding ends according to | EN 12627 | |

[SEN] Dimensions PN16
Table C.1.3

| DN | 15 | 20 | 25 | 32 | 40 | 50 | 65 | 80 | 100 | 125 | 150 | 200 | 250 | 300 | 350 | |
|------|-----|------|------|------|------|------|------|------|------|------|------|------|-------|-------|-------|-------|
| [mm] | FTF | 130 | 150 | 160 | 180 | 200 | 230 | 290 | 310 | 350 | 400 | 480 | 600 | 730 | 850 | 980 |
| | ETE | 130 | 130 | 130 | 160 | 180 | 210 | 290 | 310 | 350 | 400 | 480 | 600 | 730 | 850 | 980 |
| | D | 95 | 105 | 115 | 140 | 150 | 165 | 185 | 200 | 220 | 250 | 285 | 340 | 405 | 460 | 520 |
| | Dk | 65 | 75 | 85 | 100 | 110 | 125 | 145 | 160 | 180 | 210 | 240 | 295 | 355 | 410 | 470 |
| | nxd | 4x14 | 4x14 | 4x14 | 4x18 | 4x18 | 4x18 | 8x18 | 8x18 | 8x18 | 8x18 | 8x22 | 12x22 | 12x26 | 12x26 | 16x26 |
| | b | 16 | 18 | 18 | 18 | 18 | 18 | 18 | 20 | 20 | 22 | 22 | 24 | 26 | 28 | 30 |
| | H | 80 | 80 | 80 | 105 | 105 | 117 | 125 | 136 | 170 | 180 | 215 | 285 | 360 | 410 | 475 |
| kg | FTF | 4 | 4,5 | 5 | 8,4 | 10 | 15 | 21 | 31 | 45 | 60 | 87 | 140 | 245 | 320 | 420 |
| | ETE | 2,3 | 2,4 | 2,6 | 5 | 6 | 8 | 12 | 23 | 34 | 45 | 69 | 116 | 219 | 286 | 380 |

[SEN] Dimensions PN25
Table C.1.4

| DN | 15 | 20 | 25 | 32 | 40 | 50 | 65 | 80 | 100 | 125 | 150 | 200 | 250 | 300 | 350 | |
|------|-----|------|------|------|------|------|------|------|------|------|------|------|-------|-------|-------|-------|
| [mm] | FTF | 130 | 150 | 160 | 180 | 200 | 230 | 290 | 310 | 350 | 400 | 480 | 600 | 730 | 850 | 980 |
| | ETE | 130 | 130 | 130 | 160 | 180 | 210 | 290 | 310 | 350 | 400 | 480 | 600 | 730 | 850 | 980 |
| | D | 95 | 105 | 115 | 140 | 150 | 165 | 185 | 200 | 235 | 270 | 300 | 360 | 425 | 485 | 555 |
| | Dk | 65 | 75 | 85 | 100 | 110 | 125 | 145 | 160 | 190 | 220 | 250 | 310 | 370 | 430 | 490 |
| | nxd | 4x14 | 4x14 | 4x14 | 4x18 | 4x18 | 4x18 | 8x18 | 8x18 | 8x22 | 8x26 | 8x26 | 12x26 | 12x30 | 16x30 | 16x33 |
| | b | 16 | 18 | 18 | 18 | 18 | 20 | 22 | 24 | 24 | 26 | 28 | 30 | 32 | 34 | 38 |
| | H | 80 | 80 | 80 | 105 | 105 | 117 | 125 | 136 | 170 | 180 | 215 | 285 | 360 | 410 | 475 |
| kg | FTF | 4 | 4,5 | 5 | 8,4 | 10 | 15 | 21 | 31 | 45 | 60 | 87 | 140 | 262 | 350 | 430 |
| | ETE | 2,3 | 2,4 | 2,6 | 5 | 6 | 8 | 12 | 23 | 34 | 45 | 69 | 116 | 219 | 321 | 380 |

[SEN] Dimensions PN(\$
Table C.1.5

| DN | 15 | 20 | 25 | 32 | 40 | 50 | 65 | 80 | 100 | 125 | 150 | 200 | 250 | 300 | 350 | |
|------|-----|------|------|------|------|------|------|------|------|------|------|------|-------|-------|-------|-------|
| [mm] | FTF | 130 | 150 | 160 | 180 | 200 | 230 | 290 | 310 | 350 | 400 | 480 | 600 | 730 | 850 | 980 |
| | ETE | 130 | 130 | 130 | 160 | 180 | 210 | 290 | 310 | 350 | 400 | 480 | 600 | 730 | 850 | 980 |
| | D | 95 | 105 | 115 | 140 | 150 | 165 | 185 | 200 | 235 | 270 | 300 | 360 | 425 | 485 | 580 |
| | Dk | 65 | 75 | 85 | 100 | 110 | 125 | 145 | 160 | 190 | 220 | 250 | 310 | 370 | 430 | 510 |
| | nxd | 4x14 | 4x14 | 4x14 | 4x18 | 4x18 | 4x18 | 8x18 | 8x18 | 8x22 | 8x26 | 8x26 | 12x26 | 12x30 | 16x30 | 16x36 |
| | b | 16 | 18 | 18 | 18 | 18 | 20 | 22 | 24 | 24 | 26 | 28 | 34 | 38 | 42 | 46 |
| | H | 80 | 80 | 80 | 105 | 105 | 117 | 125 | 136 | 170 | 180 | 215 | 285 | 360 | 410 | 475 |
| kg | FTF | 4 | 4,5 | 5 | 8,4 | 10 | 15 | 21 | 31 | 45 | 60 | 87 | 150 | 276 | 360 | 455 |
| | ETE | 2,3 | 2,4 | 2,6 | 5 | 6 | 8 | 12 | 23 | 34 | 45 | 69 | 116 | 219 | 321 | 380 |

[SEN] Dimensions PN63
Table C.1.*

| DN | 15 | 20 | 25 | 32 | 40 | 50 | 65 | 80 | 100 | 125 | 150 | 200 | 250 | |
|------|-----|------|------|------|------|------|------|------|------|------|------|------|-------|-------|
| [mm] | FTF | 210 | 230 | 230 | 260 | 260 | 300 | 340 | 380 | 430 | 500 | 550 | 650 | 775 |
| | ETE | 150 | 150 | 160 | 180 | 210 | 250 | 340 | 380 | 430 | 500 | 550 | 650 | 755 |
| | D | 105 | 130 | 140 | 155 | 170 | 180 | 205 | 215 | 250 | 295 | 345 | 415 | 470 |
| | Dk | 75 | 90 | 100 | 110 | 125 | 135 | 160 | 170 | 200 | 240 | 280 | 345 | 400 |
| | nxd | 4x14 | 4x18 | 4x18 | 4x22 | 4x22 | 4x22 | 8x22 | 8x22 | 8x26 | 8x30 | 8x33 | 12x36 | 12x36 |
| | b | 20 | 22 | 24 | 26 | 28 | 26 | 26 | 28 | 30 | 34 | 36 | 42 | 46 |
| | H | 80 | 80 | 80 | 110 | 110 | 143 | 173 | 192 | 235 | 260 | 315 | 380 | 434 |
| kg | FTF | 5,1 | 6,5 | 8,5 | 15 | 16 | 27 | 35 | 58 | 71 | 143 | 150 | 375 | 643 |
| | ETE | 2,5 | 2,7 | 3 | 8 | 9 | 15 | 26 | 47 | 63 | 123 | 128 | 326 | 593 |

[SEN] Dimensions PN100
Table C.1.+

| DN | 15 | 20 | 25 | 32 | 40 | 50 | 65 | 80 | 100 | 125 | 150 | 200 | 250 | |
|------|-----|------|------|------|------|------|------|------|------|------|------|-------|-------|-------|
| [mm] | FTF | 210 | 230 | 230 | 260 | 260 | 300 | 340 | 380 | 430 | 500 | 550 | 650 | 779 |
| | ETE | 150 | 150 | 160 | 180 | 210 | 250 | 340 | 380 | 430 | 500 | 550 | 650 | 779 |
| | D | 105 | 130 | 140 | 155 | 170 | 195 | 220 | 230 | 265 | 315 | 355 | 430 | 505 |
| | Dk | 75 | 90 | 100 | 110 | 125 | 145 | 170 | 180 | 210 | 250 | 290 | 360 | 430 |
| | nxd | 4x14 | 4x18 | 4x18 | 4x22 | 4x22 | 4x26 | 8x26 | 8x26 | 8x30 | 8x33 | 12x33 | 12x36 | 12x39 |
| | b | 20 | 22 | 24 | 26 | 28 | 30 | 34 | 36 | 40 | 44 | 44 | 52 | 60 |
| | H | 80 | 80 | 80 | 110 | 110 | 143 | 173 | 192 | 235 | 260 | 315 | 380 | 454 |
| kg | FTF | 5,1 | 6,5 | 8,5 | 15 | 16 | 28 | 36 | 64 | 96 | 156 | 240 | 445 | 705 |
| | ETE | 2,5 | 2,7 | 3 | 8 | 9 | 15 | 26 | 47 | 73 | 130 | 201 | 367 | 593 |

[SEN] Dimensions PN160
Table C.1.,

| DN | 15 | 20 | 25 | 32 | 40 | 50 | 65 | 80 | 100 | 125 | 150 | 200 | |
|------|-----|------|------|------|------|------|------|------|------|------|------|-------|-------|
| [mm] | FTF | 210 | 230 | 230 | 260 | 260 | 300 | 340 | 380 | 430 | 500 | 550 | 650 |
| | ETE | 150 | 150 | 160 | 180 | 210 | 250 | 340 | 380 | 430 | 500 | 550 | 650 |
| | D | 105 | 130 | 140 | 155 | 170 | 195 | 220 | 230 | 265 | 315 | 355 | 430 |
| | Dk | 75 | 90 | 100 | 110 | 125 | 145 | 170 | 180 | 210 | 250 | 290 | 360 |
| | nxd | 4x14 | 4x18 | 4x18 | 4x22 | 4x22 | 4x26 | 8x26 | 8x26 | 8x30 | 8x33 | 12x33 | 12x36 |
| | b | 20 | 22 | 24 | 24 | 28 | 30 | 34 | 36 | 40 | 44 | 44 | 50 |
| | H | 80 | 80 | 80 | 110 | 110 | 143 | 173 | 192 | 235 | 260 | 315 | 380 |
| kg | FTF | 5,1 | 6,5 | 8,5 | 16 | 17 | 28 | 37 | 68 | 98 | 160 | 246 | 455 |
| | ETE | 2,5 | 2,7 | 3 | 8 | 9 | 15 | 26 | 47 | 73 | 130 | 201 | 367 |

Range of application

Table C.1.9

| Materials | PN | Pressure (bar) / temperature (°C) ratings according to EN 12516-1 | | | | | | | | | | | | | | | | | | | | | |
|------------------|-----|---|-------|-------|-------|-------|--------|-------|-------|-------|-------|-------|-------|-------|-------|-------|-------|-------|-------|------|------|------|------|
| | | -10 | 20 | 50 | 100 | 150 | 200 | 250 | 300 | 350 | 375 | 400 | 425 | 450 | 470 | 475 | 480 | 500 | 510 | 525 | 550 | 575 | 600 |
| 1.0460 1.0619 | 16 | 16,0 | 16,0 | 16,0 | 15,0 | 14,2 | 13,4 | 12,3 | 11,1 | 10,4 | 10,0 | 9,6 | | | | | | | | | | | |
| | 25 | 25,0 | 25,0 | 25,0 | 23,4 | 22,2 | 21,0 | 19,2 | 17,4 | 16,2 | 15,6 | 15,0 | | | | | | | | | | | |
| | 40 | 40,0 | 40,0 | 40,0 | 37,4 | 35,5 | 33,6 | 30,7 | 27,8 | 25,9 | 25,0 | 24,0 | | | | | | | | | | | |
| | 63 | 63,0 | 63,0 | 63,0 | 59,0 | 55,9 | 52,9 | 48,4 | 43,8 | 40,8 | 39,3 | 37,8 | | | | | | | | | | | |
| | 100 | 100,0 | 100,0 | 100,0 | 93,6 | 88,8 | 84,0 | 76,8 | 69,6 | 64,8 | 62,4 | 60,0 | | | | | | | | | | | |
| | 160 | 160,0 | 160,0 | 160,0 | 149,8 | 142,1 | 134,5 | 122,9 | 111,4 | 103,7 | 99,9 | 96,0 | | | | | | | | | | | |
| 1.5415 1.5419 | 16 | 16,0 | 16,0 | 16,0 | 16,0 | 15,7 | 14,6 | 13,6 | 12,7 | 11,9 | 11,7 | 11,5 | 11,1 | 10,7 | 10,5 | 10,4 | 7,3 | 6,3 | 4,5 | 2,6 | | | |
| | 25 | 25,0 | 25,0 | 25,0 | 25,0 | 24,5 | 22,8 | 21,3 | 19,8 | 18,6 | 18,3 | 18,0 | 17,3 | 16,7 | 16,4 | 16,4 | 16,3 | 11,3 | 9,9 | 7,1 | 4,0 | | |
| | 40 | 40,0 | 40,0 | 40,0 | 40,0 | 39,1 | 36,5 | 34,1 | 31,7 | 29,8 | 29,3 | 28,8 | 27,7 | 26,7 | 26,3 | 26,2 | 26,1 | 18,1 | 15,8 | 11,3 | 6,4 | | |
| | 63 | 63,0 | 63,0 | 63,0 | 63,0 | 61,6 | 57,5,5 | 53,7 | 49,9 | 46,9 | 46,1 | 45,4 | 43,7 | 42,0 | 41,4 | 41,3 | 41,1 | 28,6 | 24,9 | 17,8 | 10,1 | | |
| | 100 | 100,0 | 100,0 | 100,0 | 100,0 | 97,8 | 91,2 | 85,2 | 79,2 | 74,4 | 73,2 | 72,0 | 69,4 | 66,7 | 65,8 | 65,5 | 65,3 | 45,3 | 39,5 | 28,3 | 16,0 | | |
| | 160 | 160,0 | 160,0 | 160,0 | 160,0 | 156,6 | 146,0 | 136,4 | 126,8 | 119,1 | 117,2 | 115,3 | 111,0 | 106,8 | 105,3 | 104,9 | 104,5 | 72,6 | 63,2 | 45,2 | 25,6 | | |
| 1.7335 1.7357 | 16 | 16,0 | 16,0 | 16,0 | 16,0 | 16,0 | 16,0 | 16,0 | 14,9 | 14,4 | 13,7 | 13,1 | 12,6 | 12,0 | 11,8 | 11,6 | 10,0 | 8,9 | 7,3 | 4,7 | | | |
| | 25 | 25,0 | 25,0 | 25,0 | 25,0 | 25,0 | 25,0 | 25,0 | 23,3 | 22,4 | 21,3 | 20,4 | 19,7 | 18,7 | 18,5 | 18,1 | 15,6 | 13,9 | 11,5 | 7,3 | | | |
| | 40 | 40,0 | 40,0 | 40,0 | 40,0 | 40,0 | 40,0 | 40,0 | 37,3 | 35,9 | 4,1 | 32,7 | 31,5 | 29,9 | 29,5 | 28,9 | 25,0 | 22,3 | 18,3 | 11,7 | | | |
| | 63 | 63,0 | 63,0 | 63,0 | 63,0 | 63,0 | 63,0 | 63,0 | 58,7 | 56,5 | 53,8 | 51,4 | 49,7 | 47,2 | 46,5 | 45,5 | 39,3 | 35,1 | 28,9 | 18,5 | | | |
| | 100 | 100,0 | 100,0 | 100,0 | 100,0 | 100,0 | 100,0 | 100,0 | 93,1 | 89,8 | 85,3 | 81,6 | 78,9 | 74,9 | 73,9 | 72,2 | 62,4 | 55,8 | 45,9 | 29,3 | | | |
| | 160 | 160,0 | 160,0 | 160,0 | 160,0 | 160,0 | 160,0 | 160,0 | 149,1 | 143,7 | 136,6 | 130,7 | 126,2 | 119,8 | 118,2 | 115,6 | 99,9 | 89,3 | 73,4 | 47,0 | | | |
| 1.7383 1.7379 | 16 | 16,0 | 16,0 | 16,0 | 16,0 | 16,0 | 16,0 | 16,0 | 15,0 | 14,5 | 13,7 | 13,1 | 12,6 | 12,0 | 11,8 | 11,6 | 10,5 | 10,2 | 8,6 | 5,6 | 5,5 | 2,4 | |
| | 25 | 25,0 | 25,0 | 25,0 | 25,0 | 25,0 | 25,0 | 25,0 | 23,5 | 22,6 | 21,3 | 20,4 | 19,7 | 18,7 | 18,5 | 18,1 | 16,5 | 15,9 | 13,5 | 8,8 | 8,6 | 3,7 | |
| | 40 | 40,0 | 40,0 | 40,0 | 40,0 | 40,0 | 40,0 | 40,0 | 37,5 | 36,2 | 34,1 | 32,7 | 31,5 | 29,9 | 29,5 | 28,9 | 26,3 | 25,4 | 21,5 | 14,1 | 13,8 | 6,0 | |
| | 63 | 63,0 | 63,0 | 63,0 | 63,0 | 63,0 | 63,0 | 63,0 | 59,1 | 57,0 | 53,8 | 51,4 | 49,7 | 47,2 | 46,5 | 45,5 | 41,5 | 40,0 | 33,9 | 22,2 | 21,7 | 9,4 | |
| | 100 | 100,0 | 100,0 | 100,0 | 100,0 | 100,0 | 100,0 | 100,0 | 93,8 | 90,5 | 85,3 | 81,6 | 78,9 | 74,9 | 73,9 | 72,2 | 65,8 | 63,5 | 53,9 | 35,2 | 34,4 | 14,9 | |
| | 160 | 160,0 | 160,0 | 160,0 | 160,0 | 160,0 | 160,0 | 160,0 | 150,2 | 144,9 | 136,6 | 130,7 | 126,2 | 119,8 | 118,2 | 115,6 | 105,3 | 101,7 | 86,2 | 56,3 | 55,1 | 23,9 | |
| 1.4301 1.4308 | 16 | 16,0 | 16,0 | 16,0 | 14,8 | 13,0 | 11,2 | 10,5 | 9,9 | 9,1 | 8,9 | 8,7 | 8,5 | 8,2 | 8,1 | 8,1 | 8,0 | 7,9 | 7,8 | 7,3 | 7,1 | 6,4 | 5,0 |
| | 25 | 25,0 | 25,0 | 25,0 | 23,1 | 20,3 | 17,5 | 16,5 | 15,4 | 14,3 | 13,9 | 13,6 | 13,2 | 12,9 | 12,7 | 12,6 | 12,5 | 12,3 | 12,2 | 11,4 | 11,1 | 10,0 | 7,9 |
| | 40 | 40,0 | 40,0 | 40,0 | 37,0 | 32,5 | 28,0 | 26,3 | 24,6 | 22,8 | 22,3 | 21,7 | 21,2 | 20,6 | 20,3 | 20,2 | 20,1 | 19,7 | 19,5 | 18,2 | 17,7 | 16,0 | 12,6 |
| | 63 | 63,0 | 63,0 | 63,0 | 58,2 | 51,2 | 44,1 | 41,5 | 38,8 | 36,0 | 35,1 | 34,2 | 33,3 | 32,5 | 31,9 | 31,8 | 31,6 | 31,0 | 30,7 | 28,7 | 27,9 | 25,2 | 19,8 |
| | 100 | 100,0 | 100,0 | 100,0 | 92,4 | 81,2 | 70,0 | 65,8 | 61,6 | 57,1 | 55,7 | 54,3 | 52,9 | 51,5 | 50,6 | 50,4 | 50,2 | 49,3 | 48,7 | 45,6 | 44,3 | 40,0 | 31,5 |
| | 160 | 160,0 | 160,0 | 160,0 | 147,9 | 130,0 | 112,1 | 105,3 | 98,6 | 91,4 | 89,2 | 87,0 | 84,7 | 82,5 | 81,0 | 80,7 | 80,3 | 78,9 | 78,0 | 73,0 | 70,9 | 64,0 | 50,4 |
| 1.4408 | 16 | 16,0 | 16,0 | 16,0 | 15,2 | 13,7 | 12,1 | 11,2 | 10,3 | 9,9 | 9,6 | 9,4 | 9,2 | 9,1 | 9,0 | 9,0 | 8,9 | 8,9 | 8,8 | 8,4 | 8,3 | 7,0 | 5,8 |
| | 25 | 25,0 | 25,0 | 25,0 | 23,8 | 21,4 | 18,9 | 17,5 | 16,1 | 15,4 | 15,1 | 14,7 | 14,4 | 14,1 | 14,0 | 14,0 | 13,9 | 13,8 | 13,1 | 12,9 | 10,9 | 9,1 | |
| | 40 | 40,0 | 40,0 | 40,0 | 38,1 | 34,2 | 30,2 | 28,0 | 25,8 | 24,6 | 24,1 | 23,5 | 23,0 | 22,6 | 22,4 | 22,4 | 22,4 | 22,2 | 22,1 | 20,9 | 20,7 | 17,5 | 14,5 |
| | 63 | 63,0 | 63,0 | 63,0 | 60,0 | 53,8 | 47,6 | 44,1 | 40,6 | 38,8 | 37,9 | 37,0 | 36,2 | 35,6 | 35,4 | 35,3 | 35,2 | 34,9 | 34,8 | 32,9 | 32,6 | 27,6 | 22,8 |
| | 100 | 100,0 | 100,0 | 100,0 | 95,2 | 85,4 | 75,6 | 70,0 | 64,4 | 61,6 | 60,2 | 58,8 | 57,4 | 56,6 | 56,1 | 56,0 | 55,9 | 55,4 | 55,2 | 52,3 | 51,7 | 43,7 | 36,3 |
| | 160 | 160,0 | 160,0 | 160,0 | 152,4 | 136,7 | 121,0 | 112,1 | 103,1 | 98,6 | 96,4 | 94,1 | 91,9 | 90,5 | 89,8 | 89,6 | 89,5 | 88,7 | 88,4 | 83,7 | 82,8 | 70,0 | 58,1 |
| 1.4571 | 16 | 16,0 | 016,0 | 16,0 | 16,0 | 15,5 | 14,3 | 13,7 | 13,0 | 12,3 | 12,0 | 11,7 | 11,4 | 11,2 | 11,0 | 11,0 | 10,9 | 10,5 | 10,2 | 9,6 | 9,3 | 8,6 | 6,2 |
| | 25 | 25,0 | 25,0 | 25,0 | 25,0 | 24,2 | 22,4 | 21,4 | 20,3 | 19,3 | 18,7 | 18,2 | 17,9 | 17,5 | 17,2 | 17,2 | 17,1 | 16,5 | 15,9 | 15,0 | 14,6 | 13,5 | 9,7 |
| | 40 | 40,0 | 40,0 | 40,0 | 40,0 | 38,6 | 35,8 | 34,2 | 32,5 | 30,8 | 30,0 | 29,1 | 28,6 | 28,0 | 27,6 | 27,4 | 27,3 | 26,3 | 25,4 | 24,1 | 23,3 | 21,5 | 15,6 |
| | 63 | 63,0 | 63,0 | 63,0 | 63,0 | 60,9 | 56,4 | 53,8 | 51,2 | 48,5 | 47,2 | 45,9 | 45,0 | 44,1 | 43,4 | 43,2 | 43,0 | 41,5 | 40,0 | 37,9 | 36,7 | 33,9 | 24,5 |
| | 100 | 100,0 | 100,0 | 100,0 | 100,0 | 96,6 | 89,6 | 85,4 | 81,2 | 77,0 | 74,9 | 72,8 | 71,4 | 70,0 | 68,9 | 68,6 | 68,3 | 65,8 | 63,5 | 60,2 | 58,2 | 53,9 | 38,9 |
| | 160 | 160,0 | 160,0 | 160,0 | 160,0 | 154,6 | 143,4 | 136,7 | 130,0 | 123,3 | 119,9 | 116,5 | 114,3 | 112,1 | 110,3 | 109,8 | 109,4 | 105,3 | 101,7 | 96,3 | 93,2 | 86,2 | 62,3 |

Optional execution

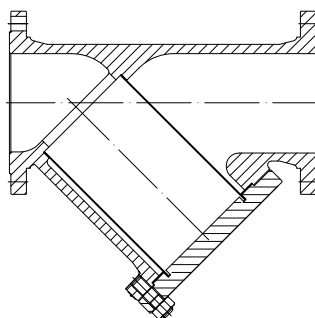

Y-Type [SENY]